

Sterling Power Products

Remote Electrical Latching Battery Isolator

Latching Technology Ignition Protected
suitable for Engine start battery or
aux battery system

640A or 480A continuous

- 2400A or 1500A intermittent (30seconds)
- 12V model operates down to 8V
- 24V models down to 16V
- 60V maximum isolated switch voltage
- Totally isolated switching voltage from control voltage
- All models are Continuous current rated
- Off power consumption = 0.2mA - 0.0002A
- On power consumption = 1.7mA - 0.0017A
- Switching power about 2A for 0.5 seconds
- OPTIONAL Key switch available for secure applications

Specification:
640A or 480A continuous
2400A or 1500A 30 sec
Isolated switch voltage 60V max
Control voltage
12 Volt 480 amps
24 Volt 640 amps

**IP68
Waterproof**

English
French
Deutsch

www.sterling-power.com
www.sterling-power-usa.com



Designed and Developed in England
Made in England

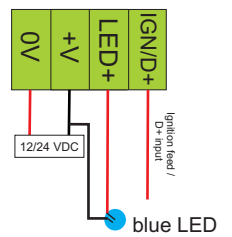

The **Latching Battery Isolator** is designed to preserve the charge of a battery by isolating the battery bank either remotely or automatically (if the pro start protect extra device is used for the automatic version). This ensures no battery drain takes place while the system is switched off.

Installation:

- Please read and understand all fitting instructions before installing the product.
- Please ensure the rating of the product is suitable for the application.
- Please ensure the cables used are of suitable size and quality for the application.

If you do not understand the instructions and how to fit the product do not try. Before proceeding with any work first remove the pos and neg for any batteries in the relevant circuits to remove the danger associated with batteries and short circuits.

First step is to unscrew the lid, there are two screws at opposing corners of the unit.

The switching unit technically consists of 2 halves, there is the control half and the switching unit, the switching unit is totally electrically isolated from the control section. I.e. you could be operating 12V on the control but you can switch up to 60V on the main switch. Also, because the switch is isolated you can fit the unit in the negative or the positive cable.

Position the unit as close to the battery bank as possible, ensure there are no wires which are bypassing the unit and are connected directly to the battery bank as isolating the battery bank with a bypass wire is rather pointless.

Position the main switch in the main cable run, try not to extend the heavy d/c cables to fit in a place which could cause extra unnecessary voltage drop, usually as close to the battery bank as possible.

Decide if you wish to break the pos or neg cable, then simply break the cable and connect the unit into the cable. Next decide where you wish to connect the remote on/off switch and the on light, its advisable not to position in direct view of driver as at night the light may prove to be bright, the remote light does not need to be fitted for the unit to work. Decide if you want to use the small switch provided or a key switch to lock the power and make the unit more secure.

Marine emergency override circuit. In some applications where this product may be used there may be a requirement for an emergency bypass, this would be most common on say a boat, to achieve this simply add a high current key switch in parallel with the remote circuit so in case of emergency the unit can be simply passed.

Connect as per the drawing below, to power up the unit the screw terminals '+V' and '0V' need to be connected to a permanent 12V (or 24V depending on the control voltage) power source (if the control voltage is 12V for that unit) or a 24V source (if the control voltage is 24V for that unit). Do not connect a 24V source to a 12V unit - check the product label. N.B. A typical source would be the starter battery.

Connecting the 2 way momentary switch

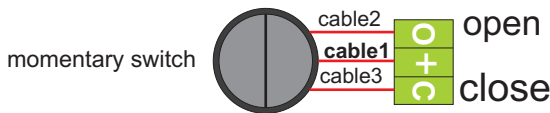

Connect the momentary switch to the units left hand terminal block 'O' '+' 'C' using three cables (not provided): Cable1, Cable2 & Cable3. Cable1 must be connected to the central contact on the momentary switch and the central terminal '+' on the unit. Cable2 connects to C and cable3 connects to 'O'. For UP on the switch as engage, connect Cable3 to the bottom terminal on the switch, with Cable2 connected to the top terminal on the switch. If you require DOWN on the switch to engage the relay, swap Cable2 and Cable3 on the switch.

To test if the latching relay is opening and closing the circuit as you wish look at the blue LED on the unit. If the blue LED is on, the relay is close circuited 'Engaged' and, if the blue LED is off, then the relay is open circuited 'Disengaged'. Or, do a simple voltage test across the contacts to ensure the unit is operational, also, expect to hear a clunk from the box as the latching relay opens and closes.

Connecting the ignition/D+ and external LED

The ignition / D+ is simply there as a safety precaution. The use of an ignition/signal feed is not essential for the functioning of the product. It's a safety system, it's highly recommended this is connected if the box is used on an engine start battery, this prevents the unit from being accidentally activated in the event of a engine running as this could cause irreparable damage to the alternator and engine management system. If used on a standard aux battery installation where there are no repercussions if accidentally switched off then do not worry about this safety interlock circuit.

If there is a live ignition / d+ to the unit the relay will simply not open circuit for fears of damaging your engine/alternator.

Alternator d+ (61.L) or ignition feed which is best? For a manual operation system, the d+ or ignition feed would be fine, however, if the unit is used with the Start Pro Tech automatic control box then the ignition feed is much better than the d+, the reason is that if the auto system is used then the fan belt or alternator fail then the d+ signal would fail. This would then cause the system's voltage to drop and eventually the automatic system would see the voltage drop on the battery and engage the safety trip i.e. open circuit the battery, where an ignition feed would keep the system engaged and may allow the vehicle to return home to base without the unit operating.

Engage LED indicator, this is a 6V operational unit and is designed to be used in conjunction with our product, the pos and neg cables of the external LED must be connected to LED+ (positive) and 0V (common negative) on the terminal block. Cable not supplied.

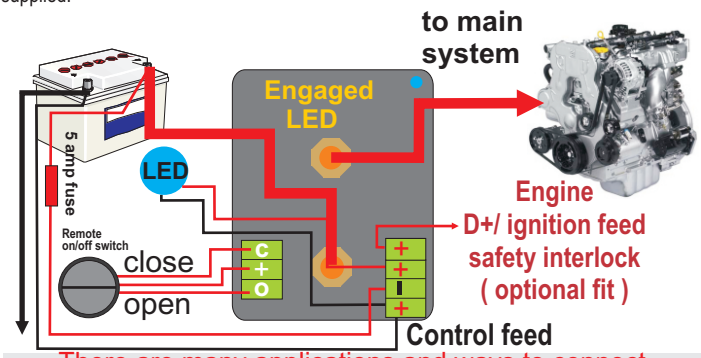

There are many applications and ways to connect this product, this is a simple example

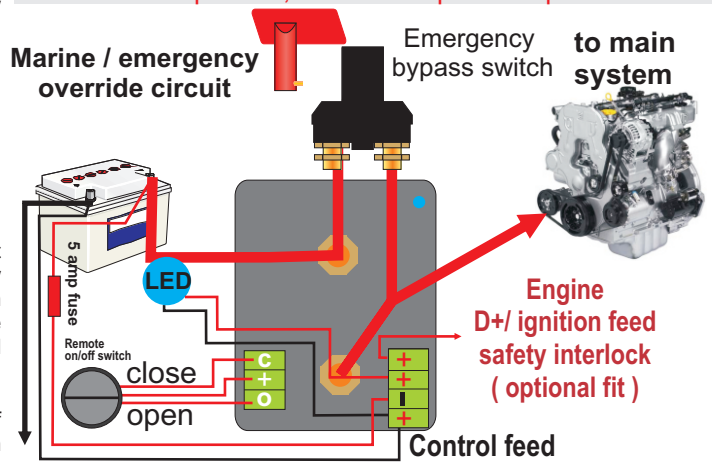

Extra momentary switch (one supplied standard in each kit)
Sterling power part number **ELS1**

Key operated switch with 2 keys (optional extra)
Sterling power part number **ELKS1**